

AW winches are designed to position and hold accommodation ladders, ship to shore or between vessels and offshore installations.

Constructed in accordance with SOLAS requirements for international shipping, the range features a dynamically and statically self braking worm gearbox and emergency hand crank. Each type may be configured for single or twin rope operation and powered by means of an electric or pneumatic motor.

EMCÉ also can provide a range of pilot ladder winches, please consult our sales department.

Standard features:

- Self braking worm gear transmission
- SOLAS compliance
- IP 56 TENV motor protection
- Rotary vane or radial piston motor
- Steel drum (not grooved) with one or two cable fixing point(s) at flange
- Two drum supports
- Emergency hand crank
- Double layer 2 component conservation, colour BS 20 (Medium Blue)
- Pneumatic versions with hand control valve

- Alternative drum dimensions / split drums / additional rope anchors / etc.
- Drum guard
- Marine / offshore coating systems

Available control options:

- Electric or pneumatic control systems
- Limit switch

Available options:

- Band brake, manual or automatic fail safe
- Increased motor protection IP 68 TENV
- Alternative supply voltages
- Grooved drum
- Drum pressure roller
- Alternative speeds

Winch type	W.L.L. kg.	Holding force kg.	Holding force kg.	Recomm. rope diam. mm.	Speed 1st layer m/min.	Drumcap. 3rd layer m.	Motor power 400 VAC kW	Pressure drop in bar	Flow in l/sec.
AW 500 ES	500	1200	1500	8	6	30	1,5		
	2 X 250	1200	1500	6	6	2 X 25	1,5		
AW 1000 ES	1000	2000	3000	10	7,5	35	3		
	2 X 500	2000	3000	8	7,5	2 X 20	3		
AW 1500 ES	1500	3000	4000	12	9,5	50	4		
	2 X 750	3000	4000	10	9,5	2 X 40	4		
AW 500 LS	500	1200	1500	8	6	30		6	40
	2 X 250	1200	1500	6	6	2 X 25		6	40
AW 1000 LS	1000	2000	3000	10	7,5	35		6	80
	2 X 500	2000	3000	8	7,5	2 X 20		6	80
AW 1500 LS	1500	3000	4000	12	9,5	50		6	120
	2 X 750	3000	4000	10	9,5	2 X 40		6	120

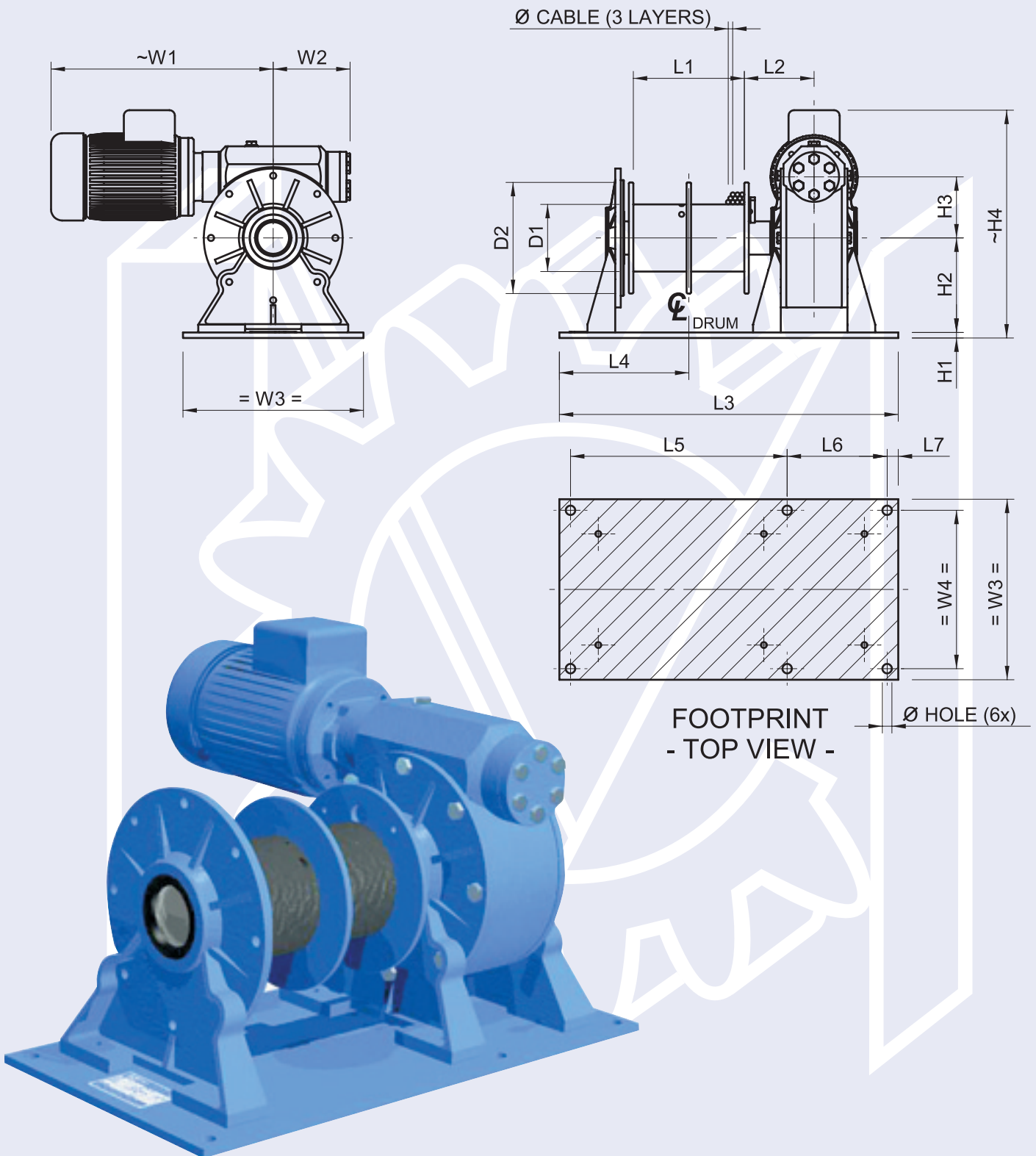

Type	Mass (kg)	D1	D2	L1	L2	L3	L4	L5	L6	L7	H1	H2	H3	H4	W1	W2	W3	W4	Hole \varnothing
AW 500	85	121	200	200	125,5	610	233	390	180	20	10	170	110	410	400	132	325	285	17
AW 1000	195	159	320	250	154,5	710	260	470	200	20	15	220	150	522	487	154	410	360	17
AW 1000	275	195	370	300	180	850	317,5	565	235	25	15	254	177,5	570,5	548	205	440	380	20

