

CREATING POWER SOLUTIONS.



  
**Silent  
PACK**

2L41C  
3L41C | 3L43C  
4L41C | 4L42C | 4L43C

**Hatz Diesel**

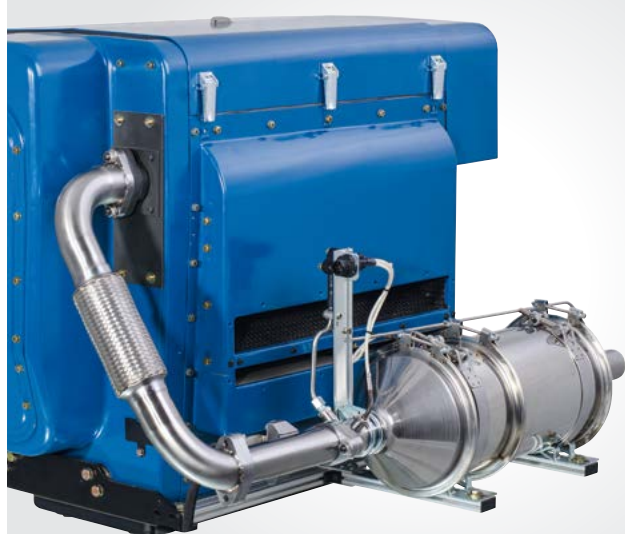

#### Exhaust gas recirculation (EGR)

For years already the Hatz 4L42C has been successfully fitted with a robustly designed exhaust gas recirculation system for fulfillment of the emission standards in Europe and the USA. To satisfy the current standards, the 3L43C and 4L43C are also fitted with the proven exhaust emission technology for NO<sub>x</sub> reduction.

#### Diesel particulate filter (DPF)

Exhaust stages 97/68/EC Stage IIIB and EPA Tier 4 final currently in force require the use of a diesel particulate filter (DPF) with integrated oxidation catalyst. Hatz has developed a closed filter system with active regeneration in operation.

# Hatz L-series: Economic, fail-safe, quiet

These are the qualities that characterize L-series engines. Their rugged design gives them an extremely long service life. The crankcase and single cylinders are made from indestructible gray cast iron, the power train and bearing points are generously dimensioned giving them an extremely long service life. This allows L-series engines to be operated in even remote areas or for applications without constant monitoring.

## Environmental aspects

Hatz diesel engines in the L/M series are the only exhaust-compliant, air-cooled engines available in this power range. The 4L42C with exhaust gas recirculation (EGR), the 3L43C as well as the 4L43C are also fitted with an electronic speed governor and removable diesel particulate filter (DPF). Engines in the L43 series fulfil the strict emission standards of EU regulation 97/68/EC Stage IIIB as well as the regulations of the US EPA Tier 4 final.

## Fuel consumption and cold start

L-series engines are among the most efficient in the market. Fuel consumptions of 232 g/kWh testify to the optimized combustion process. 6-hole VCO nozzles, as well as the monoblock single stage pumps, and the optimized combustion chamber geometry all make their contribution to this. Without a pre glow system the engines start reliably as low as -10 °C; with a pre glow system and corresponding resources even -32 °C is no problem.

## Unique automatic engine protection

The integrated, intelligent, mechanical automatic engine protection protects the engine. When a cooling fan malfunctions, there is not enough oil, or the inclination is too high, the engine is automatically stopped to prevent engine damage.

## The SilentPack

The innovative Hatz SilentPack is still unrivaled today by competitors. Radiated noise emission is reduced by 90 % due to use of the engine capsule. This means, 10 SilentPack engines emit no more noise than a single non-encapsulated engine. The capsule consists of sheet metal with structure-borne sound insulation that is mounted on the engine. All control and service points have easy outside accessibility. Due to the cooling air circulation, SilentPack engines – like all other Hatz engines – can be used under virtually all climatic conditions.

## Robust and durable design



Hatz engines are designed for an exceptionally long service life. The best possible materials and components coupled with uncompromising quality assurance contribute to the fact that Hatz engines have

been setting the benchmark in the industry for many years when it comes to robustness and service life. And should, contrary to expectations, a spare part actually be needed, more than 500 service partners in 115 countries are available quickly and dependably with advice and assistance as well as original spare parts.

Sales area [exhaust certificate]	IFN rating ICFN rating F/IFN/ICFN rating					
	2L41C	3L41C	3L43C	4L41C	4L42C	4L43C
USA [EPA/CARB constant speed] [r.p.m.]	1500-2000	-	1500-3000	-	-	1500-3000
USA [EPA 2-speed] [r.p.m.]	1500-2000	-	-	-	-	-
USA [EPA variable speed] [r.p.m.]	2000	-	1500-3000	-	-	1500-3000
EU [constant speed] [r.p.m.]	1500-3000	1500-3000	-	1500-1800	1800-3000	-
EU [variable speed] [r.p.m.]	1500-3000	1500-3000	-	1500-1800	-	2200-3000
India CPCB I [Genset] [r.p.m.]	1500	1500	-	1500	-	-
All others [non-EPA] [r.p.m.]	1500-3000	1500-3000	-	1500-3000	-	-

## Technical data, Performance Table

Technical data		2L41C	3L41C	3L43C	4L41C	4L42C	4L43C
Type	Air-cooled 4-stroke diesel engine with direct injection						
Number of cylinders	2	3	3	4	4	4	
Exhaust gas after-treatment			EGR & DPF		EGR	EGR & DPF	
Bore x stroke [mm / inches]	102 x 105 4.02 x 4.13	102 x 105 4.02 x 4.13	102 x 105 4.02 x 4.13	102 x 105 4.02 x 4.13	102 x 105 4.02 x 4.13	102 x 105 4.02 x 4.13	
Displacement [l / cu.in.]	1.716 / 104.7	2.574 / 157	2.574 / 157	3.432 / 209.4	3.432 / 209.4	3.432 / 209.4	
Engine	Mean piston speed at 3000 rpm [m/s / ft/min]	10,5 / 2.067					
	Compression ratio	20.0 : 1	20.0 : 1	20.8 : 1	20.0 : 1	20.8 : 1	20.8 : 1
	Lub. oil consumption, related to full load	max. 1 % of fuel consumption					
	Oil filling max / min [l / US qts]	4.5 / 2.5 4.8 / 2.6	8.0 / 5.0 8.5 / 5.3	8.0 / 5.0 8.5 / 5.3	13.0 / 5.0 13.7 / 5.3	13.0 / 5.0 13.7 / 5.3	13.0 / 5.0 13.7 / 5.3
	Speed control						
	· Lowest idle speed r.p.m.	900	900	1.000	900	1.000	1.000
	· Static speed droop	approx. 5% at 3000 r.p.m.					
Installation information	Amount of combustion air at 3000 rpm approx. <sup>1)</sup> [m <sup>3</sup> /min / cu.ft./min]	2.6 / 92	3.9 / 138	3.9 / 138	5.2 / 184	5.2 / 184	5.2 / 184
	Amount of cooling air at 3000 rpm approx. <sup>1)</sup> [m <sup>3</sup> /min / cu.ft./min]	29 / 1.024	39 / 1.377	39 / 1.377	42 / 1.483	42 / 1.483	42 / 1.483
	Mass moment of inertia J [kgm <sup>2</sup> / lb.ft <sup>2</sup> ]						
	· SAE-flywheel 8"	0.64 / 15.2	0.65 / 15.4	0.65 / 15.4	0.67 / 15.9	0.67 / 15.9	0.67 / 15.9
	· flywheel for F+S clutch	0.49 / 11.6	0.50 / 11.9	0.50 / 11.9	0.51 / 12.1	0.51 / 12.1	0.51 / 12.1
	Starter	12 V - 2.7 kW — 24 V - 4.0 kW					
	Alternator charging current at 3000 / 1500 r.p.m.	14 V - 60 A / 42 A — 28 V - 40 A / 28 A					
Battery capacity [min / max Ah]	12 V - 88 / 143 Ah — 24 V - 55 / 110 Ah						
Weight	Engine with electric start 12 V or 24 V [kg / lbs.]	303 / 668	363 / 800	365 / 805 <sup>2)</sup>	433 / 955	435 / 959	435 / 959 <sup>2)</sup>

<sup>1)</sup> For other speeds there is a linear reduction in the air requirement.

<sup>2)</sup> Weight without DPF

Performance Table		[r.p.m.]	2L41C	3L41C	3L43C	4L41C	4L42C	4L43C
Vehicle power acc. to DIN ISO 1585 [kW / hp]	3000		27.0 / 36.7	40.9 / 55.6	— / —	54.2 / 73.7	— / —	— / —
	2600		25.3 / 34.4	38.2 / 52.0	— / —	50.8 / 69.1	— / —	— / —
	2300		23.1 / 31.4	35.3 / 48.0	— / —	46.3 / 63.0	— / —	— / —
Blocked ISO brake horsepower [IFN] for heavily intermittent loading acc. to ISO 3046-1 [kW / hp]	3000		24.4 / 33.2	36.7 / 50.0	34.0 / 46.2	48.8 / 66.4	46.1 / 62.7	44.2 / 60.1
	2600		23.2 / 31.6	35.2 / 47.9	32.6 / 44.3	45.9 / 62.4	43.5 / 59.2	42.0 / 57.1
	2300		23.5 / 32.0	35.9 / 48.8	33.0 / 44.9	47.0 / 63.9	45.1 / 61.3	42.8 / 58.2
	2000		20.9 / 28.4	31.2 / 42.4	29.0 / 39.4	41.0 / 55.8	40.0 / 54.4	38.2 / 51.9
	1800		18.7 / 25.4	28.0 / 38.1	26.3 / 35.8	37.0 / 50.3	37.5 / 51.0	35.3 / 48.0
	1500		15.0 / 20.4	22.9 / 31.1	21.3 / 29.0	30.0 / 40.8	— / —	28.8 / 39.2
ISO standard power output [ICXN] [10% overload permissible] [kW / hp]	3000		22.0 / 29.9	33.0 / 44.9	— / —	43.9 / 59.7	— / —	— / —
	2600		20.9 / 28.4	31.7 / 43.1	— / —	41.3 / 56.2	— / —	— / —
	2300		21.2 / 28.8	32.3 / 43.9	— / —	42.3 / 57.5	— / —	— / —
Blocked ISO standard power output (no overload permissible) acc. to ISO 3046-1. [kW / hp] For constant speed and constant load [ICFN]	2000		18.8 / 25.6	28.1 / 38.2	— / —	36.9 / 50.2	— / —	— / —
	1800		16.8 / 22.8	25.2 / 34.3	— / —	33.3 / 45.3	— / —	— / —
	1500		13.5 / 18.4	20.6 / 28.0	— / —	27.0 / 36.7	— / —	— / —

# Power, torque and fuel consumption

## 2L41C

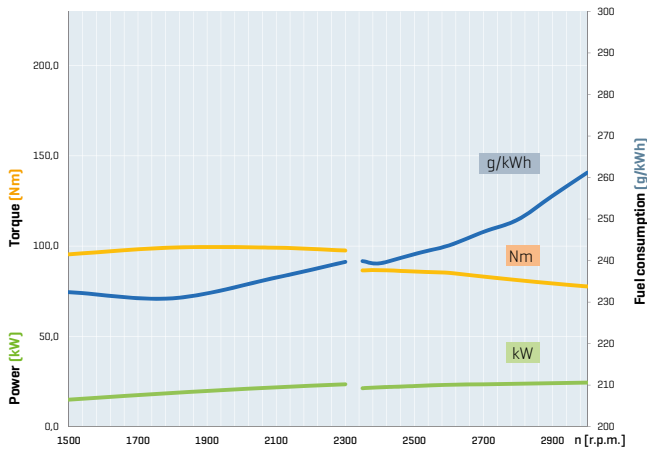

### Power ratings

For the power ratings, refer to standard reference conditions of ISO 3046-1 (IFN): + 25 °C (77 °F), 100 kPa, relative humidity 30 %. The specified power is reached during the running-in period, and can be 5 % less on delivery. Power reduction acc. to ISO 3046-1. Standard values: More than 100 m above sea level approx. 1 % per 100 m. Above 25 °C approx. 4 % per 10 °C. The power taken from the alternator also has to be added to the power calculation.

## 3L41C

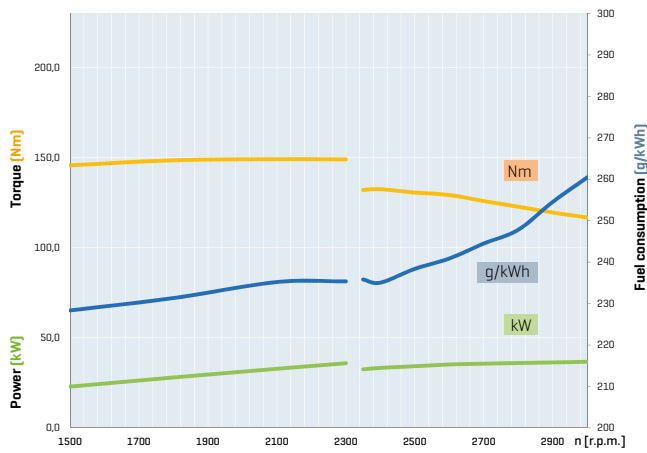

## 3L43C

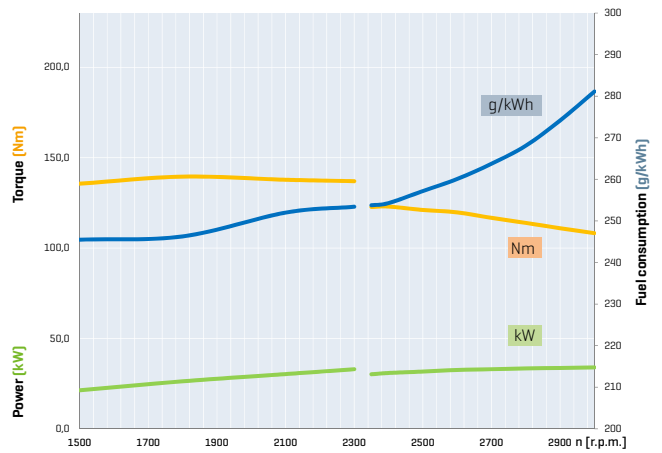

## 4L41C

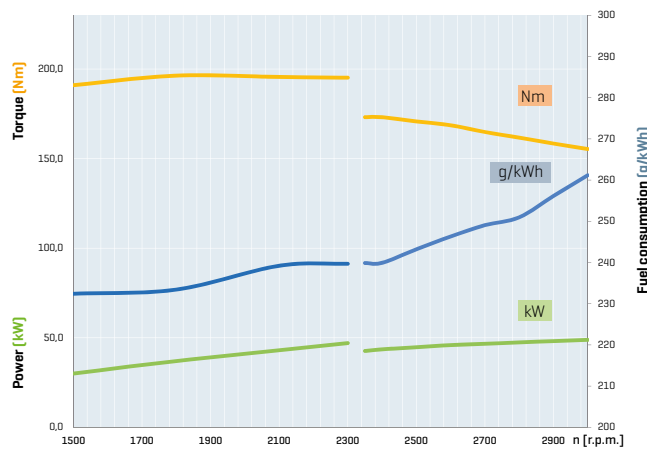

## 4L42C

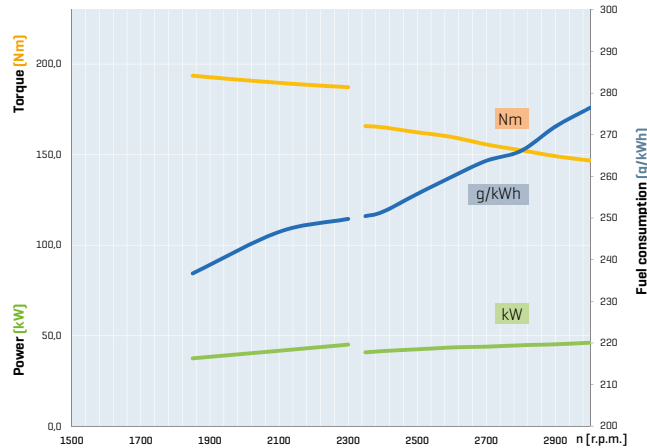

## 4L43C

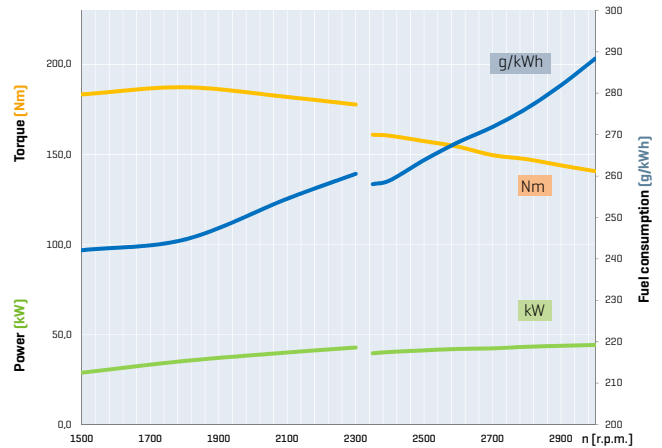

## Maintenance and operating points

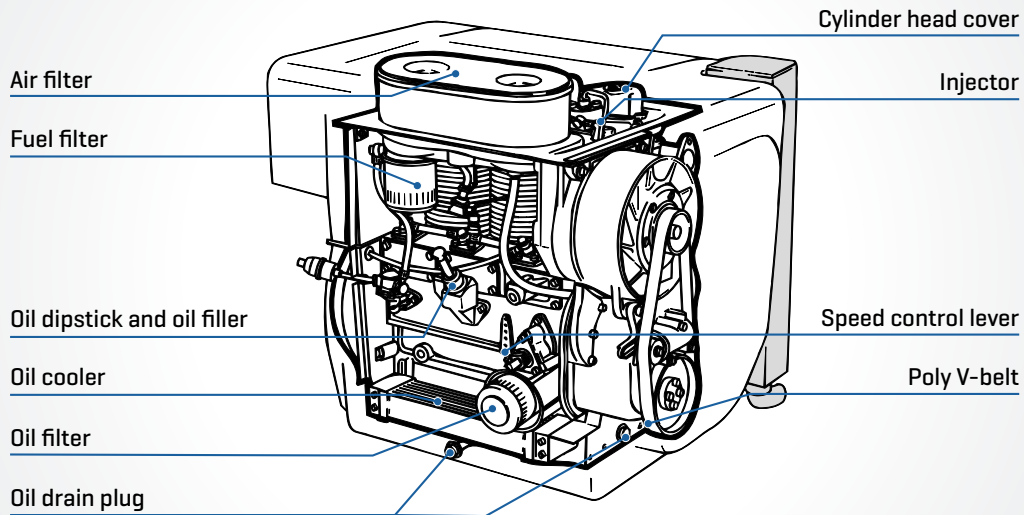

Accessible after opening the capsule: Injector, cylinder head cover, air filter

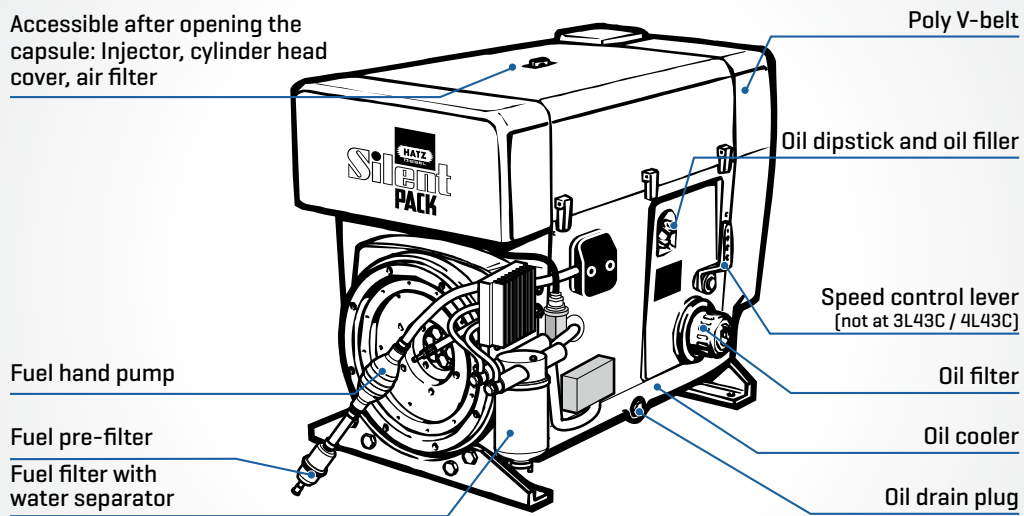

## Power take off

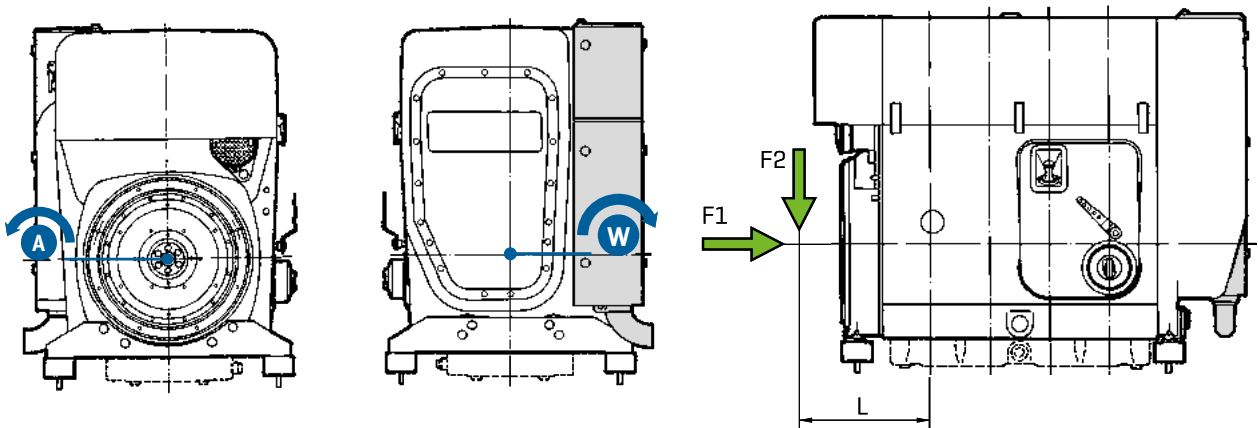

Power take off		2-4L41C	4L42C	3-4L43C
Transmittable torque	A	Full torque	Full torque	Full torque
	W	70 Nm with engine speed	70 Nm with engine speed	70 Nm with engine speed
Permissible load	F1	2700 N	2700 N	2700 N
	F2	$F_2 = \frac{400\,000}{L \text{ (mm)} - 73} \text{ [N]}$	$F_2 = \frac{400\,000}{L \text{ (mm)} - 73} \text{ [N]}$	$F_2 = \frac{400\,000}{L \text{ (mm)} - 73} \text{ [N]}$

## Dimensions

### 2L41C | 3L41C | 4L41C

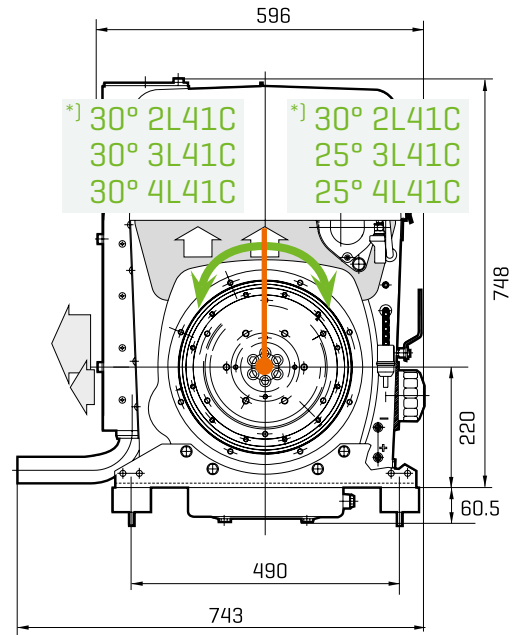
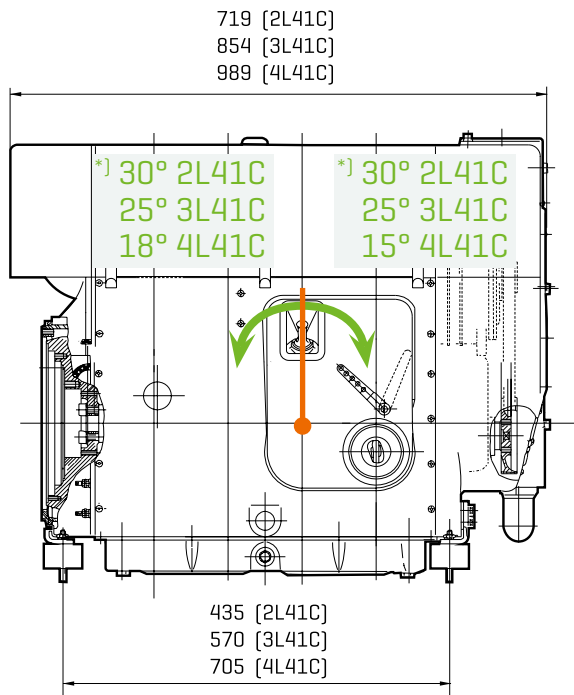

### 3L43C | 4L42C | 4L43C

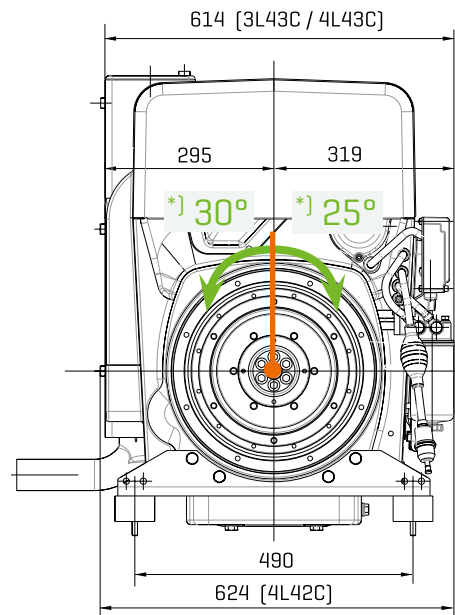
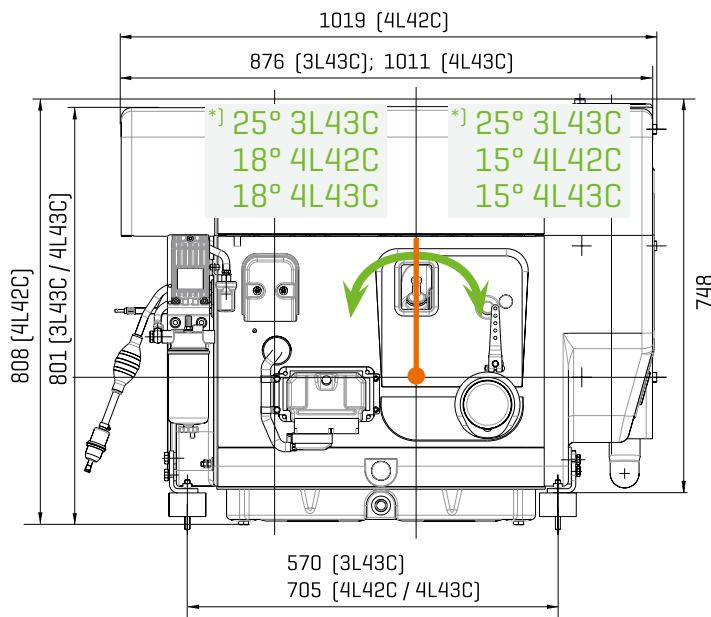

### Diesel particulate filter (DPF)

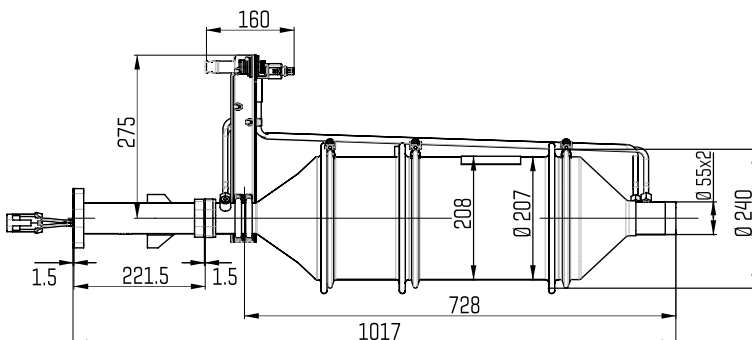

Spread of box dimensions  $\pm 3$  mm due to tolerance.  
Drawings with detail and connection dimensions as PDF and DXF can be found at [www.HATZ-DIESEL.com](http://www.HATZ-DIESEL.com).

Dimensions 3L43C and 4L43C without DPF and exhaust muffler.

\*] Max. tilt position

Motorenfabrik Hatz GmbH & Co. KG  
Ernst-Hatz-Str. 16  
94099 Ruhstorf a.d. Rott  
Germany  
Phone +49 8531 319-0  
Fax +49 8531 319-418  
marketing@hatz-diesel.de  
www.hatz-diesel.com



**CREATING POWER SOLUTIONS.**

700 384 99 EN -02.14-1.5 Printed in Germany  
Modifications, which serve the technical  
improvements, are reserved.